

Total number of printed pages-4

44 (3) DSAL BCA-HC-3026

2021

(Held in 2022)

DATA STRUCTURE AND ALGORITHMS

Paper : BCA-HC-3026

Full Marks : 60

Time : Three hours

The figures in the margin indicate full marks for the questions.

1. Answer the following questions as directed : 1×10=10
 - (a) STACK is a FIFO data structure. (True or False)
 - (b) $O(1)$ means ; complexity time is constant. (True or False)
 - (c) Quicksort is not a Divide-and-Conquer strategy. (True or False)
 - (d) What is abstract data type ?
 - (e) Mention *two* applications of queue data structure.

Contd.

- (f) What is the time complexity of insertion sort algorithm ?
- (g) What do you mean by depth of a tree ?
- (h) _____ linked list does not have any NULL links. *(Fill in the blank)*
- (i) Which data structure is used for implementing recursive algorithm ?
- (j) Find the postfix form of the expression $(A + B) * (C * D - E) * F / G$.

2. Answer the following questions : **(any five)**

2×5=10

- (a) What is stack overflow and underflow ? Explain with example.
- (b) Write the address translation of 1-dimensional and 2-dimensional arrays.
- (c) Write the advantages of linked-list over arrays.
- (d) Define Big Oh and Big Theta notation.
- (e) What do you mean by structured approach towards problem solving ?
- (f) Represent the given matrix using column-major ordering.

3. Answer the following questions : **(any five)**
3×5=15

(a) Construct the binary expression tree from the given expression (in postfix format)

$ABC * + DEF + * +$

(b) Perform inorder, postorder and level-order traversal of the given binary tree :

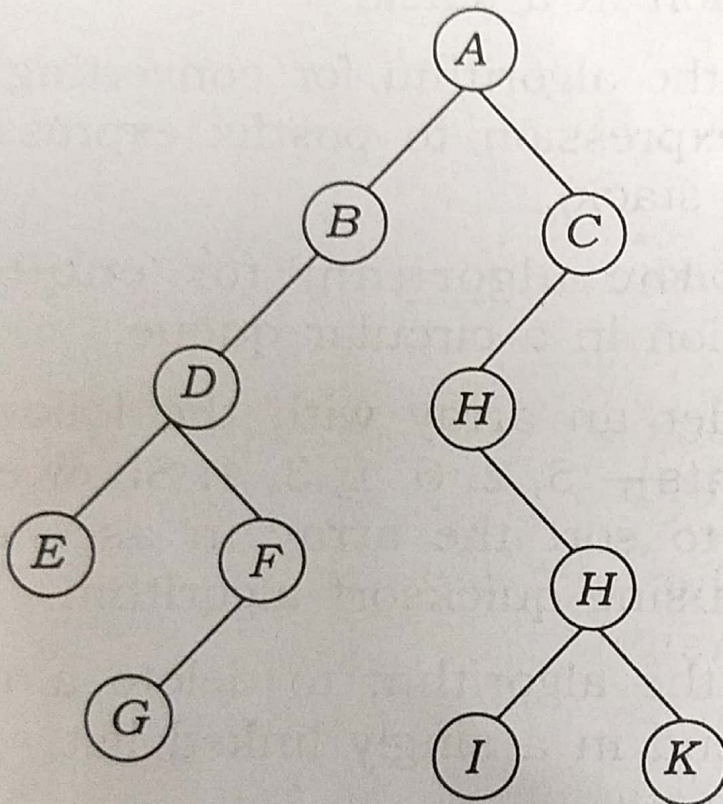

(c) Construct the binary search tree from the given integer sequence — $\{5, 3, 1, 9, 7, 18, 10\}$. Perform postorder traversal of the tree.

(d) What is circular queue? What are the advantages of circular queue over linear queue?

- (e) Write the algorithm for DFS traversal on a graph.
- (f) Compare the time complexity of linear search and binary search.
4. Answer the following questions : **(any three)**
5×3=15
- (a) Write the algorithm for push and pop operation in a stack.
- (b) Write the algorithm for converting an infix expression to postfix expression (using stack).
- (c) Write the algorithm for enqueue operation in a circular queue.
- (d) Consider an array with the following elements — 5, 2, 6, 1, 3, 4. Show each steps to sort the array in ascending order using quicksort algorithm.
- (e) Write the algorithm to delete a node from end in a singly linked list.
5. Write a program to implement the evaluation of a postfix expression. 10

OR

Write a program to implement the heapsort algorithm.